



At Original Saw we strive to make your life and your production line easier and less complicated. We manufacture the S-Series of accessories to compliment not only our line of cutting equipment, but to work with a wide variety of wood and metalworking applications; any time material needs to be moved or measured moving into or out of a processing application. Our stock line of roller tables, flat extension tables, and accessory stands have many mounting brackets available to mount into your existing application line, or if you prefer, add an adjustable leg set to make a free standing table. See website for full product line details and new additions to the line.

Accessories

S Series Accessories



cutoff

www.originalsaw.com

Original Saw Company
465 Third Ave SE
Britt, IA 50423 USA
800.733.4063 ph
641.843-3868 ph
641.843.3869 fx
www.originalsaw.com
customerservice@originalsaw.com

Simple Solutions to streamline your measuring

Manual Measuring systems provide solid everyday measuring solutions to simply and streamline your cutoff processes. Get rid of the tape measure and improve your accuracy and repeatability with Original Saw's S-Series Accessories.

Roller table highlights and new revisions

S Series Accessories

Need roller tables to move your raw material into and out of a cutting or processing application? All of our roller tables and flat material handling tables have a rear flange to allow the S-Series measuring systems to attach directly, making installation a snap, whether it is a new system or the measuring option is added later. The Series consist of material handling roller tables, flat extension tables, manual measuring systems, and miter saw stands that all work together to make a simple cutting solution that will work for your application. Some of the components are shown at the right.

- 1) mounting brackets (vary by type of machine)
- 2) Roller table new heavier gage and bolt together design drastically lowers shipping costs
- 3) Adjustable leg kits—New heavier wider design
- 4) Manual measuring systems—see next page

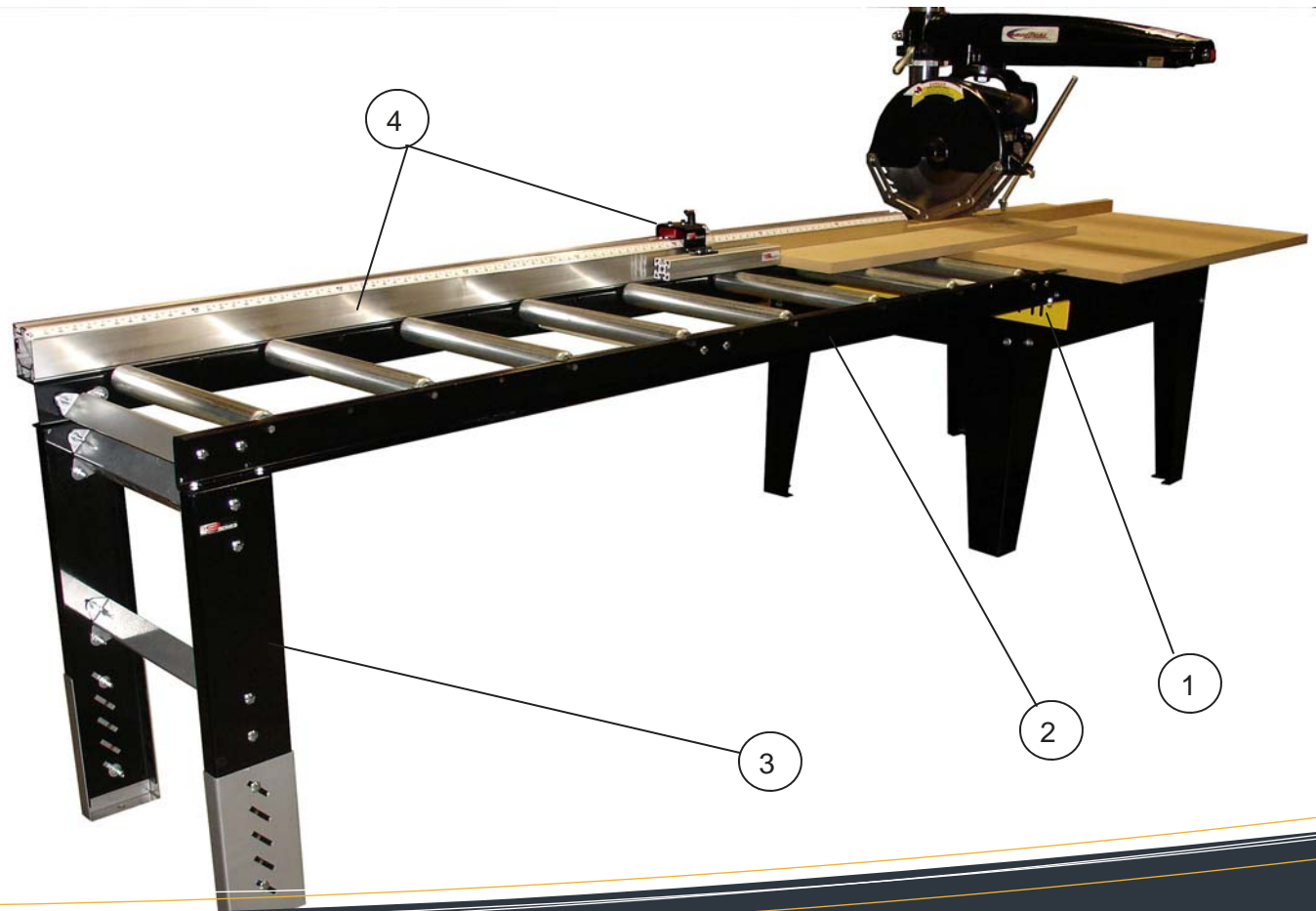

Simple positioning and material handling solutions that work for your business.

SIMPLIFYING

.....Measuring

.....Material Handling

040030 Roller Extension Tables

Material Handling roller tables

These tables are available with rollers set on 12" centers or 6" centers for smaller material as well as UHMW coated rollers for your material that needs a non-metallic surface to roll over. Such as with all the S Series accessories the roller tables integrate with the measuring systems to make a complete material handling solution. The newly redesigned legs are now wider and easier to adjust to the required height of your application.

Material Handling roller tables

Steel rollers zinc plated

040030-01 : 8' section with 8 roller set on 12" centers

040030-02 : 8' section with 15 roller set on 6" centers

Steel roller with UHMW Sleeve

040031-01 : 8' section with 8 roller set on 12" centers

040031-03 : 8' section with 15 rollers set on 6' centers

Note; See website for series specific kit part numbers

Each kit contains:: 8 foot roller table frame with bolt in brackets, 8 or 15 rollers, 1 adjustable leg kit, and mounting bracket. The kit breaks down into a UPS or Fed Ex sized package for easy shipping.



S Series roller extension tables



WE'VE WORKED WITH A WIDE RANGE OF APPLICATIONS. HOW CAN WE HELP YOU?

Simplifying one application at a time.

PROVEN

.....

DEPENDABLE

.....

RELIABLE

040032 Extension Tables

Material Handling extension tables

These new tables are available in 4 foot and 8 foot sections are over 20" wide. These extension tables will handle the applications where rollers are not required. They are constructed of 11 gage steel and powder coated with a textured finish to handle the day to day use. They can be bolted together end to end to achieve any length required for your application in multiples of 4 or 8 foot. As will the roller tables they will accept the S Series measuring systems. These tables coupled with a measuring system and an Original Radial arm saw make a flexible precision cutting station .

Material Handling extension tables

040032-01 : 4' extension table kit

040032-03 : 8' extension table kit

Each kit contains:: Extension table , 2 adaptor brackets, 1 adjustable leg kit, 1 frame mounting bracket., and hardware



S Series flat extension tables

www.originalsaw.com

 simplifying

cutoff

Simple positioning solutions that work for your business.

SIMPLIFYING

.....Measuring

.....Material Handling



040039-00 Accessory Stand

040039-00 Accessory Stand

Original Saw developed this accessory stand to compliment our S Series line of manual measuring systems, material handling roller tables and extension tables. The stand is constructed of 12 and 14 gage formed steel with a texture powder coat finish on the table top and contrasting smooth gloss black on the legs. This will give smaller shops and schools the option of using our industrial measuring systems and material handling roller and extension tables to set up a stationary cutting station for their favorite miter saw.

040039-00 Accessory Stand

Includes ; formed steel top, legs, leg braces and hardware.

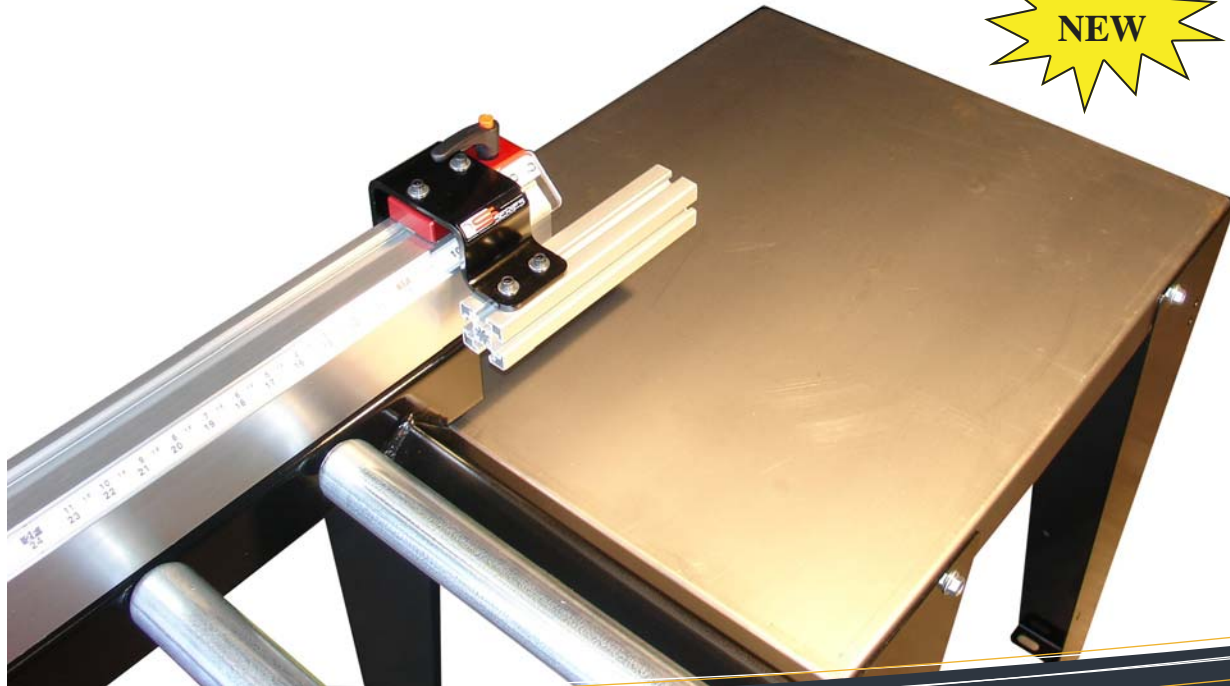

WE'VE WORKED WITH A WIDE RANGE OF APPLICATIONS. HOW CAN WE HELP YOU?

Simplifying one application at a time.

PROVEN

.....

DEPENDABLE

.....

RELIABLE

Simple positioning solutions that work for your business.

SIMPLIFYING

.....Measuring

.....Material Handling

900705 Manual Measuring Systems

Measuring Systems

Original Saw's S-Series manual measuring systems are a rock-solid manual measuring system manufactured using heavy duty ribbed aluminum extrusion, available in 4', 8', 12', 16' and 32' applications for both left and right side mounting. These packages are normally off the shelf and ready to ship in 24 hours. The fence rails are packaged in 4' and 8' sections and are pinned together to reach the longer 12', 16' and up to 32' lengths. Each kit contains the extruded aluminum rail, sliding assembly with lens adjustable aluminum foot, end caps for the rails, and precision measuring tape. See website for full product offerings and details on new additions to the line.

Measuring Systems

Each Measuring System kit contains:

- 1 Extruded Rail
- 2 Slider Assembly
- 3 Viewing lens
- 4 Precision scale
- 5 Adjustable foot
- 6 Mounting kit, end caps, hardware (not shown)

www.originalsaw.com

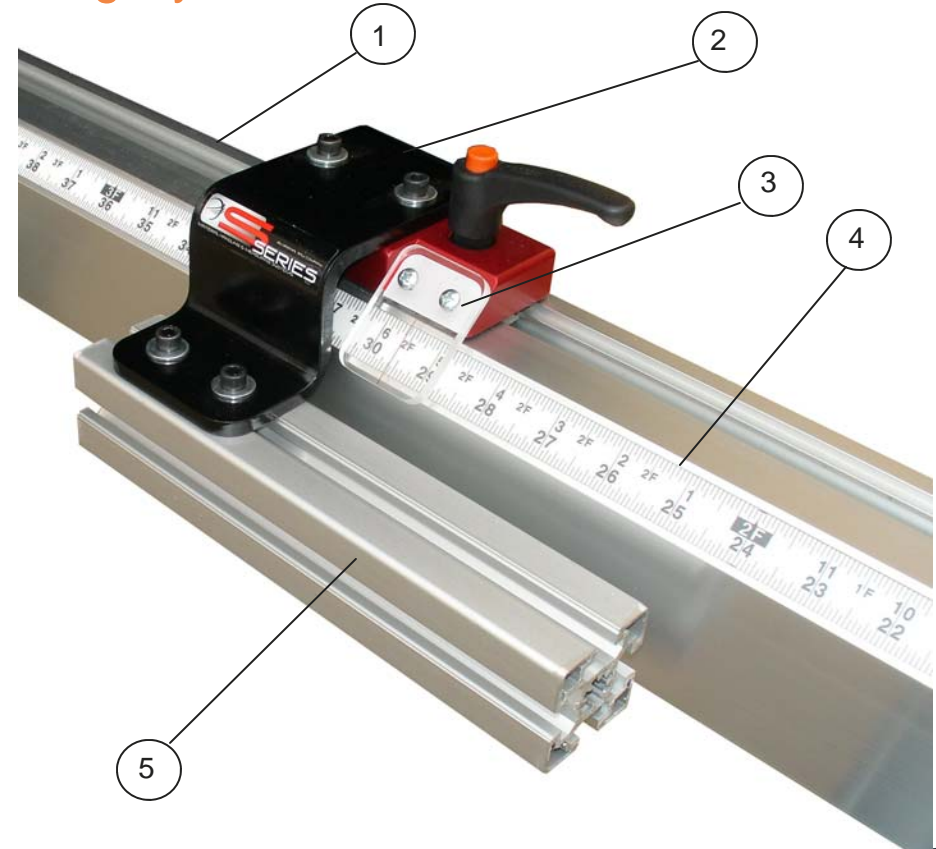

S Series measuring systems

flexible measuring solutions for your applications ...

simplifying

cutoff

SIMPLIFYING

.....Measuring
.....Material Handling

Measuring Systems

- 900705-00 : 4' measuring system left side mounting
- 900705-02 : 4' measuring system right side mounting
- 900705-01 : 8' measuring system left side mounting
- 900705-03 : 8' measuring system right side mounting
- 900705-05 : 16' measuring system left side mounting
- 900705-07 : 16' measuring system right side mounting
- 900705-09 : 24' measuring system left side mounting
- 900705-11 : 24' measuring system right side mounting
- 900705-13 : 32' measuring system left side mounting
- 900705-15 : 32' measuring system right side mounting

Note: Systems shown as "left side mount" have measuring tapes that read from right to left and the units showing "right side mounting" have tapes that read from left to right.



Custom Application : S Series measuring system set up to read both strait cuts as well as 45 degree miter cuts.



WE'VE WORKED WITH A WIDE RANGE OF APPLICATIONS. HOW CAN WE HELP YOU?

Simplifying one application at a time.

PROVEN

.....

DEPENDABLE

.....

RELIABLE

SIMPLIFYING

-Cutoff
-material handling
-measuring

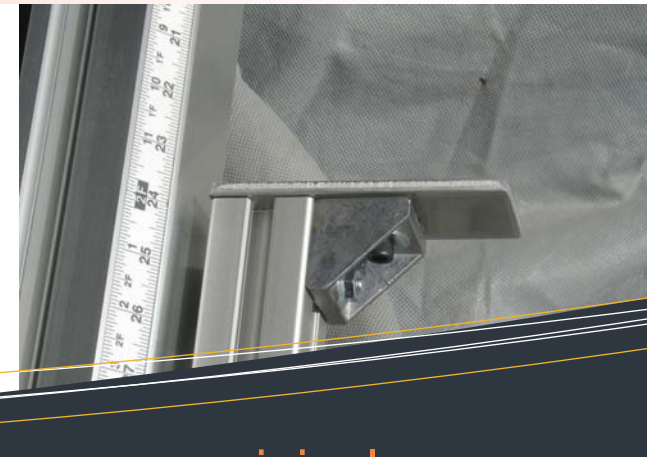

Original Saw[™] Family of Products

Original Saw Company

465 Third Ave SE

Britt, IA 50423 USA

800.733.4063 ph

641.843-3868 ph

641.843.3869 fax

www.originalsaw.com

customerservice@originalsaw.com

- 3700 Series Cutoff Saws
- 3600 Series Horizontal Beam Saws
- Super Duty Metal Cutting Series
- Super Duty Series Radial Arm Saws
- Heavy Duty Series Radial Arm Saws
- Contractor Duty Series Radial Arm Saws
- S - Series Manual Measuring Systems
- S - Series Material Handling Tables
- Electric Arbor Motors
- Power Drive Carriage Systems
- Pneumatic Clamping Systems

www.originalsaw.com

simplifying

cutoff